

## ACCESSORI OPZIONALI | OPTIONAL ACCESSORIES

<b>PRF-04</b>	Piano a rulli mm 400x500 L x W (ingresso/uscita)	Infeed/Outfeed free roller conveyor mm 400x500 L x W
<b>PRF-08</b>	Piano a rulli mm 800x500 L x W (ingresso/uscita)	Infeed/Out-feed free roller conveyor mm 800x500 L x W
<b>PRF-FH</b>	Lama ferma scatole in ingresso (opzionale per PRF-04 o PRF-08)	Box holding device infeed (optional for PRF-04 or PRF-08)
<b>PRF-BS</b>	Barra ferma-scatole in uscita (opzionale per PRF-04 o PRF-08)	Box stopper outfeed (optional for PRF-04 or PRF-08)
<b>PRE 50-3</b>	Rulliera estensibile a rotelle	Extensible free wheels conveyor
<b>GTA17</b>	Set di 4 gambe con ruote e freno da Ø 80mm.	Leg with casters Ø 80mm
<b>GTA18</b>	Set di 4 gambe regolabili (0 / 300 mm) con ruote da Ø 100mm	Legs extension adjustable 0 / 300 mm with casters Ø 100mm
<b>GTA11</b>	Kit Stop & Go (temporizzazione cinghie)	Drive belt timed stop (energy saving kit)
<b>GTA06</b>	Kit RFN segnalazione rottura / fine nastro	Tape brake/end alarm kit
<b>GTA03</b>	chiudi-3-falde	Three-Flap Closer
<b>GTA10</b>	Versione opposta	Opposite version
<b>GTA-SC</b>	Colore speciale	Special color
<b>1-PH</b>	Versione monofase	Single-phase version

## CARATTERISTICHE TECNICHE | TECHNICAL DATA

Teste nastranti standard   <b>TU2.1</b>	Standard tape heads   <b>TU2.1</b>
Alimentazione elettrica   <b>3-Fase, 400V/50Hz</b>	Electrical power supply   <b>Three-phase, 400V/50Hz</b>
Potenza installata   <b>0,18 kW</b>	Installed power   <b>0,18 kW</b>
Livello di protezione elettrica   <b>IP55</b>	Electrical protection level   <b>IP55</b>
Temperatura d'esercizio   <b>Da +5°C fino a +35°C</b>	Service temperature   <b>From +5°C to +35°C</b>

Capacità produttiva   <i>Productivity</i>	<b>GT 50S</b>
Velocità di trasferimento scatola   <i>Box transfer speed</i>	<b>1300/1500 scatole-boxes/h</b>
	<b>18 mt/min</b>

Dati indicativi in funzione delle caratteristiche scatole | *Indicative data depending on the box configuration*

## DIMENSIONI | DIMENSIONS

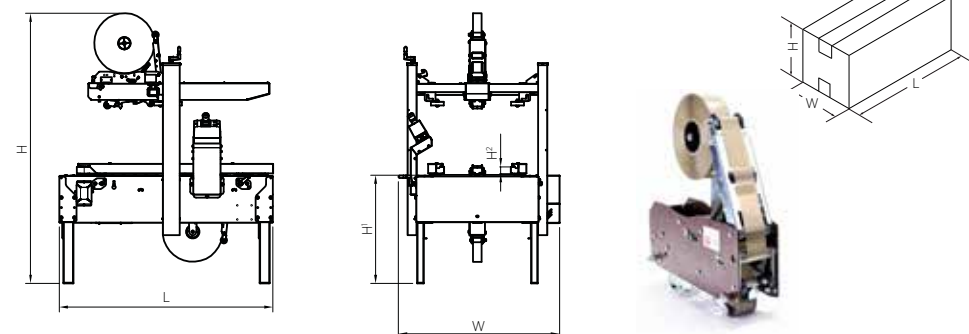

<b>GT 50S - Standard</b>	
<b>L</b>	Min 150 / ∞
<b>W</b>	Min 100 / Max 510 mm
<b>H</b>	Min 40 / Max 510 mm
<b>GT 50S - TU2.1</b> (Teste nastranti   Standard tape heads)	
Min <b>W</b>	=170mm x <b>H</b> 40mm <b>L</b> = da 150mm a ∞
Min <b>W</b>	=110mm x <b>H</b> 70mm <b>L</b> = da 150mm a ∞
<b>GT 50S - TUE</b> (Teste nastranti   Standard tape heads)	
Min <b>W</b>	=90mm x <b>H</b> 70mm <b>L</b> = da 150mm a ∞
Min <b>W</b>	=150mm x <b>H</b> 40mm <b>L</b> = da 150mm a ∞

	<b>L</b>	<b>W</b>	<b>H</b>	<b>H<sup>1</sup></b>	<b>H<sup>2</sup></b>	<b>Kg</b>
<b>GT 50S</b>	1280 mm	965,5 mm	1700 max mm	650/750 mm	40 mm	130

Le caratteristiche tecniche possono essere soggette a variazioni senza preavviso | *Specifications subject to change without notice*

Altre lingue disponibili | *Other languages available: www.eenamarchetti.it* |



**PACBRO S.r.l.**

Via Don Milani, 1 | 20025 Legnano (MI), Italy | Tel. +39 0331 599518 | Fax +39 0331 545291

[www.eenamarchetti.it](http://www.eenamarchetti.it) [info@elenamarchetti.it](mailto:info@elenamarchetti.it) [elenamarchettipackagingmachines](https://www.facebook.com/elenamarchettipackagingmachines)



# GOLDTAPE 50 S

**NASTRATRICE SEMI-AUTOMATICA  
REGOLAZIONE MANUALE SULLE DIVERSE DIMENSIONI SCATOLA**

**SEMI-AUTOMATIC CARTON SEALER  
MANUALLY ADJUSTABLE ON THE DIFFERENT BOX SIZES**



PACKAGING MACHINES





GOLDTAPE 50S

TESTE NASTRANTI DISASSATE  
OFFSET TAPING UNITS



## FOCUS

GOLDTAPE 50S Nastratrice semi-automatica a dimensionamento manuale, che sigilla con nastro autoadesivo le falde inferiori e superiori di scatole in cartone di tipo americano.

- **MACCHINE ROBUSTE ED AFFIDABILI**
- **TESTE NASTRANTI PERFORMANTI CON MOVIMENTI MORBIDI E LINEARI**
- **REGOLAZIONI SEMPLICI E VELOCI**
- **MINIMA MANUTENZIONE**

GOLDTAPE 50S semi-automatic manually adjustable carton sealer for the tape sealing of the top and bottom flaps of American type boxes.

- **HEAVY DUTY & RELIABLE MACHINES**
- **SMOOTH AND EFFICIENT OPERATING TAPING HEADS**
- **QUICK AND EASY CHANGEOVERS**
- **MINIMAL SERVICING**

CINGHIE RIBASSATE  
REDUCED HEIGHT BELTS

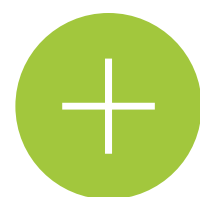

## PUNTI CHIAVE / KEY FEATURES

- **Concepita per nastrire scatole particolarmente basse** | *Designed for particularly low taping boxes*
- **Due cinghie laterali di trascinamento ribassate ad un'altezza di 40 mm, azionate da un unico motore**  
*Two side driving belts height 40 mm and powered by a single motor*
- **Versione standard equipaggiata con due teste nastranti TU2.1**  
*Standard version equipped with two TU2.1 taping heads*
- **Può montare differenti modelli di teste nastranti, in funzione della dimensione minima della scatola**  
*Can be equipped with different models of taping heads, depending on the minimum size of the boxes*
- **Associata ad un formatore semiautomatico GF056/GF056 P in ingresso e una rulliera in uscita costituisce una completa ed efficiente stazione di imballaggio**  
*Combined upstream with a semi-automatic case erector GF056/GF056 P and downstream with a roller conveyor or flexi extendable conveyor it becomes a complete and efficient packing station*
- **Tutte le macchine sono prodotte in Italia e rispettano le normative CE**  
*All the machines are entirely manufactured in Italy according to EEC Standards*

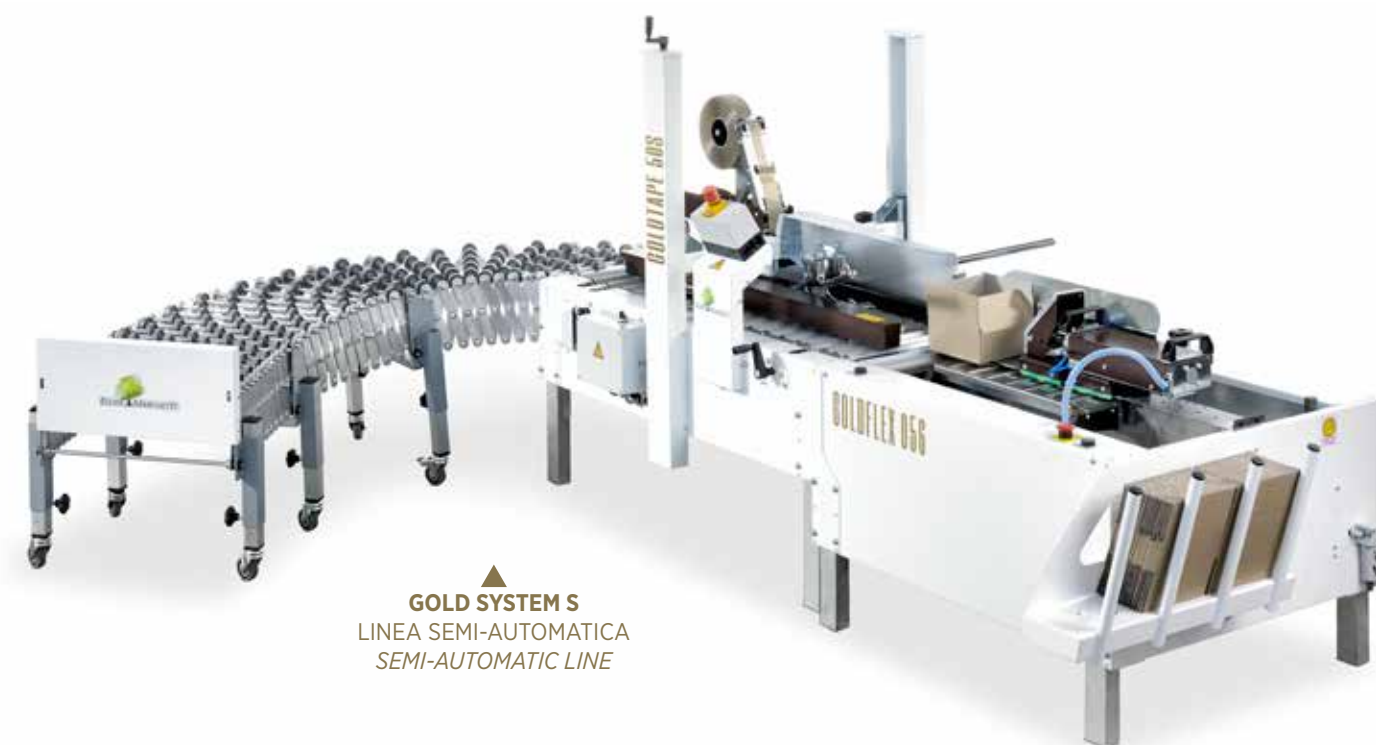

GOLD SYSTEM S  
LINEA SEMI-AUTOMATICA  
SEMI-AUTOMATIC LINE